

Model T2 Precision Rotary Torque Transducer

Why the Interface model T2 Precision Rotary Torque Transducer is the best in class:

- Capacities from 0.1 to 20K Nm (0.88 to 177K lb-in)
- ± 5 VDC output
- Digital electronics
- Stainless steel shaft
- 12 to 28 VDC supply
- Contactless
- 10 kHz sample rate



T2 Precision Rotary Torque Transducer

OPTIONS

Speed & Angle Measurement - 360 Pulse TTL, 2-Tracks 90° Offset, Available on capacities up to 1,000 Nm only
 Speed Output - 60 Pulse TTL, 1-Track, Available on capacities 2,000 Nm & above
 ± 10 V Torque Output
 RS485
 High RPM
 Keyed Shafts
 SAE Sized Shafts

SPECIFICATIONS

ACCURACY – (MAX ERROR)

Combined Error-% FS ± 0.1
 Nonrepeatability-% ± 0.02

TEMPERATURE

Effect on Zero-% RO/ $^{\circ}$ C ± 0.02
 Effect on Output-%/ $^{\circ}$ C ± 0.01
 Rated Range- $^{\circ}$ C+5 to +45
 Operating Range- $^{\circ}$ C0 to +60

ELECTRICAL

Output-VDC ± 5
 Bandwidth, Hz3 kHz-3dB
 Calibration Signal-% RO100
 Supply Voltage-VDC.....12 to 28
 Supply Current-mA60
 Electrical Connection8 or 12-pin

MECHANICAL

Safe Overload-% RO200
 Cyclic Load Rating-% RO..... ± 70 peak
 Max Speed - rpmVaries with capacity, see table
 Shaft.....Stainless steel
 HousingAluminum

T2 Precision Rotary Torque Transducer - Capacities 0.1 to 15 Nm

DIMENSIONS

Nominal Torque				
Capacity (Nm)	0.1, 0.2, 0.5, 1, 2, 5		10, 15	
Equivalent (lb-in)	0.88, 1.77, 4.43, 8.85, 17.7, 44.3		88.5, 133	
	inch	mm	inch	mm
①	3.35	85	3.35	85
②	0.71	18	0.71	18
③	0.3148/ 0.3144	8g6	0.3935/ 0.3931	10g6
④	0.67	17	0.67	17

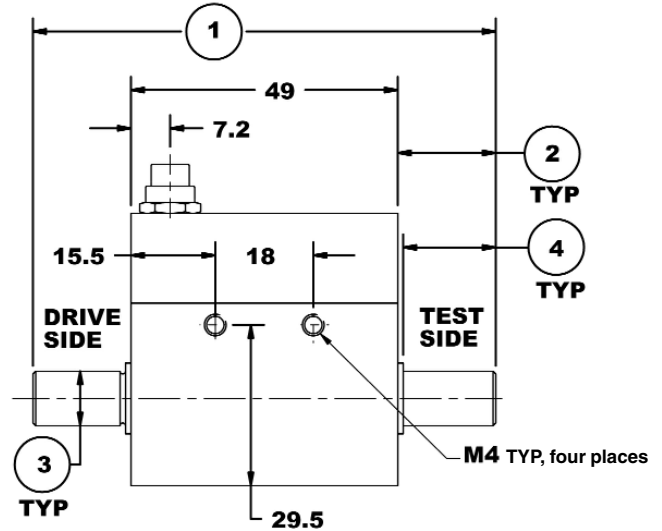
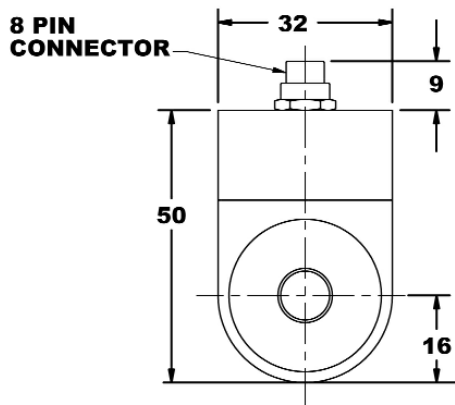

Dimensions in mm

T2 Precision Rotary Torque Transducer - Capacities 20 to 500 Nm

DIMENSIONS

Nominal Torque						
Capacity (Nm)	20, 30		50, 100		200, 500	
Equivalent (lb-in)	177, 265		443, 885		1.77K, 4.43K	
	inch	mm	inch	mm	inch	mm
①	2.81	71.5	2.81	71.5	2.85	72.5
②	4.39	111.5	5.81	147.5	6.28	159.5
③	0.79	20	1.50	38	1.71	43.5
④	0.7084/ 0.7080	18 h6	0.7084/ 0.7080	18 h6	1.2595/ 1.2589	32 h6
⑤	0.71	18	1.42	36	1.50	38
⑥	2.32	59	2.32	59	2.99	76
⑦	0.79	20	0.79	20	0.79	20
⑧	1.57	40	1.57	40	2.28	58
⑨	0.20	5	0.20	5	0.24	6
⑩	1.63	41.5	1.63	41.5	1.16	29.5
⑪	0.59	15	0.59	15	0.87	22

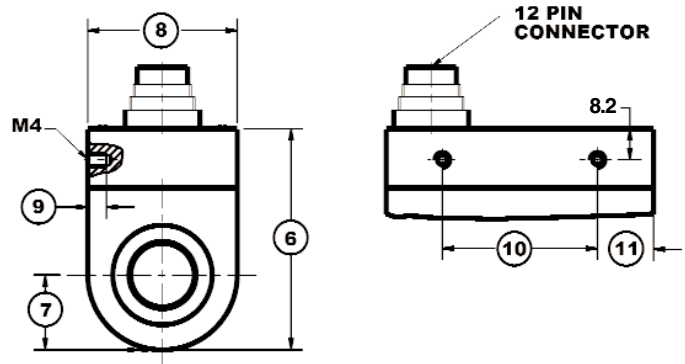
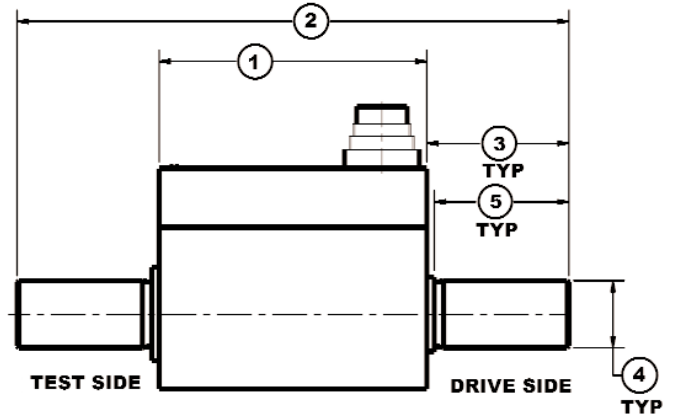

T2 PRECISION ROTARY TORQUE TRANSDUCER PERFORMANCE PARAMETERS

CAPACITY (Nm)	MAX RPM		SPRINGRATE (Nm/rad)	MOMENT OF INERTIA, J (Kgxm ²)		MAX THRUST LOAD (N)
	Standard	Special		Drive Side	Test Side	
0.1	10,000	15,000	1.0	1.9x10 ⁻⁶	2.8x10 ⁻⁷	15
0.2	10,000	15,000	1.0	1.9x10 ⁻⁶	2.8x10 ⁻⁷	20
0.5	10,000	15,000	9.9	1.9x10 ⁻⁶	2.8x10 ⁻⁷	30
1	10,000	15,000	9.9	1.9x10 ⁻⁶	2.8x10 ⁻⁷	40
2	10,000	15,000	3.6x10 ²	1.9x10 ⁻⁶	2.9x10 ⁻⁷	50
5	10,000	15,000	6.5x10 ²	1.9x10 ⁻⁶	3.0x10 ⁻⁷	50
10	10,000	15,000	8.5x10 ²	2.1x10 ⁻⁶	3.9x10 ⁻⁷	50
15	10,000	15,000	8.5x10 ²	2.1x10 ⁻⁶	3.9x10 ⁻⁷	100
20	8,000	15,000	4.5x10 ³	1.2x10 ⁻⁵	9.9x10 ⁻⁶	300
30	8,000	15,000	4.5x10 ³	1.2x10 ⁻⁵	9.9x10 ⁻⁶	1,000
50	6,000	15,000	8.5x10 ³	1.3x10 ⁻⁵	1.2x10 ⁻⁵	1,600
100	6,000	12,000	8.5x10 ³	1.3x10 ⁻⁵	1.2x10 ⁻⁵	2,600
200	6,000	12,000	6.7x10 ⁴	1.0x10 ⁻⁴	9.0x10 ⁻⁵	3,200
500	5,000	10,000	7.8x10 ⁴	1.0x10 ⁻⁴	9.2x10 ⁻⁵	7,500
1,000	4,000	7,000	3.1x10 ⁵	1.6x10 ⁻³	1.1x10 ⁻³	10,000
2,000	3,500	5,500	7.2x10 ⁵	5.3x10 ⁻³	4.3x10 ⁻³	18,000
5,000	3,500	5,500	8.0x10 ⁵	5.4x10 ⁻³	4.3x10 ⁻³	32,000
10,000	3,000	5,000	1.2x10 ⁶	4.1x10 ⁻²	3.9x10 ⁻²	125,000
20,000	3,000	5,000	2.1x10 ⁶	4.1x10 ⁻²	4.3x10 ⁻²	200,000

ELECTRICAL CONNECTION

8-PIN T2 ELECTRICAL CONNECTION		
Pin	Function	Description
1	Supply (+)	12-28 VDC
2	Supply (GND)	0 VDC
3	Signal (+)	±5 VDC
4	Signal (GND)	0 VDC
5	Cal. Control	L < 2.0 / H > 3.5 V
6	Option Angle A	TTL
7	Option Angle B	TTL
8	NC	-

12-PIN T2 ELECTRICAL CONNECTION			12-PIN T2 RS485 OPTION	
Pin	Function	Description	Function	Description
A	NC	-	NC	-
B	Option Angle B	TTL	Option Angle B	TTL
C	Signal (+)	±5 VDC	NC	-
D	Signal (GND)	0 VDC	NC	-
E	Supply (GND)	0 VDC	Supply (GND)	0 VDC
F	Supply (+)	12-28 V	Supply (+)	12-28 VDC
G	Option Angle A	TTL	Option Angle A	TTL
H	NC	-	NC	-
J	NC	-	RS485 Option	RS485 (B)
K	Cal. Control	L < 2.0 V / H > 3.5 V	NC	-
L	NC	-	RS485 Option	RS485 (A)
M	Housing		Housing	